

HTGR Technology Course for the Nuclear Regulatory Commission

May 24 – 27, 2010

Module 5d

Prismatic HTGR Refueling Design

Outline

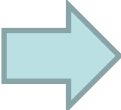
- 
- **Prismatic refueling system functions and requirements**
 - **Refueling system design description**
 - **Fort St. Vrain experience**
 - **Used fuel management plan**

Prismatic Refueling System Key Functions

- **Remove and replace fuel in reactor**
- **Provide interim used fuel storage**
- **Receive, inspect, and store new fuel**
- **Provide for long term storage and disposal**
- **Provide control and inventory accountability**
- **Replace selected reflector elements**
- **Perform in-core inspection and maintenance**

Prismatic Refueling System Key Requirements

- **Minimize refueling time consistent with fuel cycle time allocation for planned outage**
- **Provide for storage of used fuel and discharged reflectors from 10 years of plant operations plus one core volume including reflectors**
- **Provide space to expand storage facility to accommodate used fuel and reflectors discharged over the plant life**
- **Provide for expanding used fuel storage facility without impacting power production**
- **Provide interface with US DOE used fuel disposition system**

OUTLINE

- Prismatic refueling system functions and requirements
- ➔ • Refueling system design description
- Fort St. Vrain experience
- Used fuel management plan

Refueling System Arrangement for 4-Module HTGR Plant

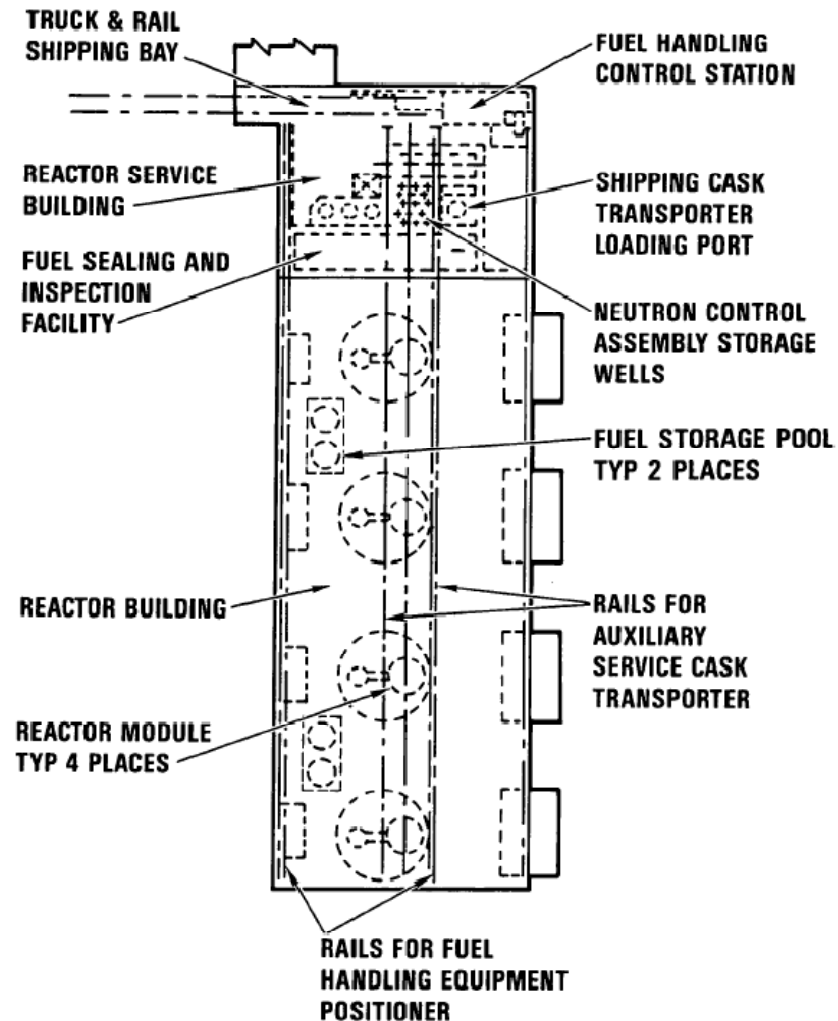

Refueling System Equipment - MHTGR

- **Main refueling equipment items are:**
 - Fuel Handling Equipment Positioner
 - Fuel Handling Machine
 - Fuel Handling Equipment Support Structure
 - Fuel Transfer Cask
- **Fuel handling machine grapples fuel elements from core for placement in fuel transfer cask**
- **Fuel transfer cask transfers the fuel elements to/from fuel storage pool**

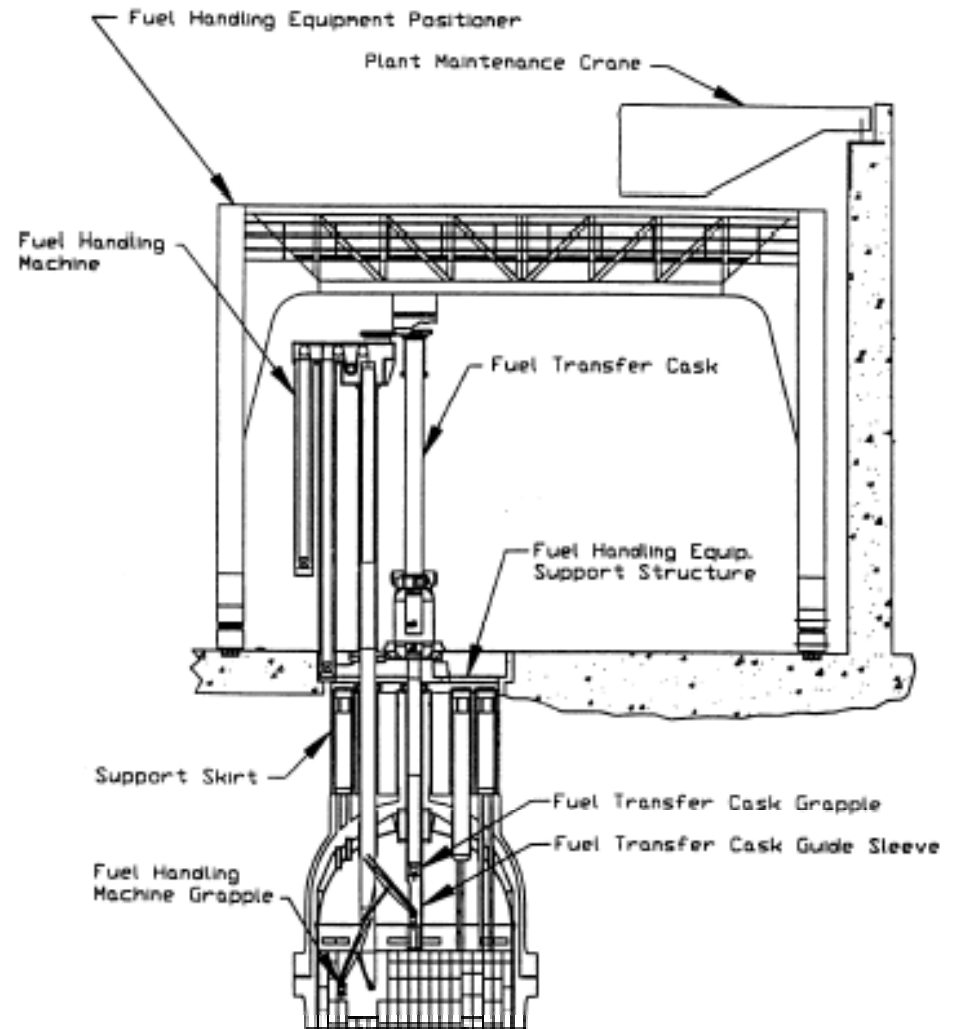

Fuel Handling Machine – MHTGR

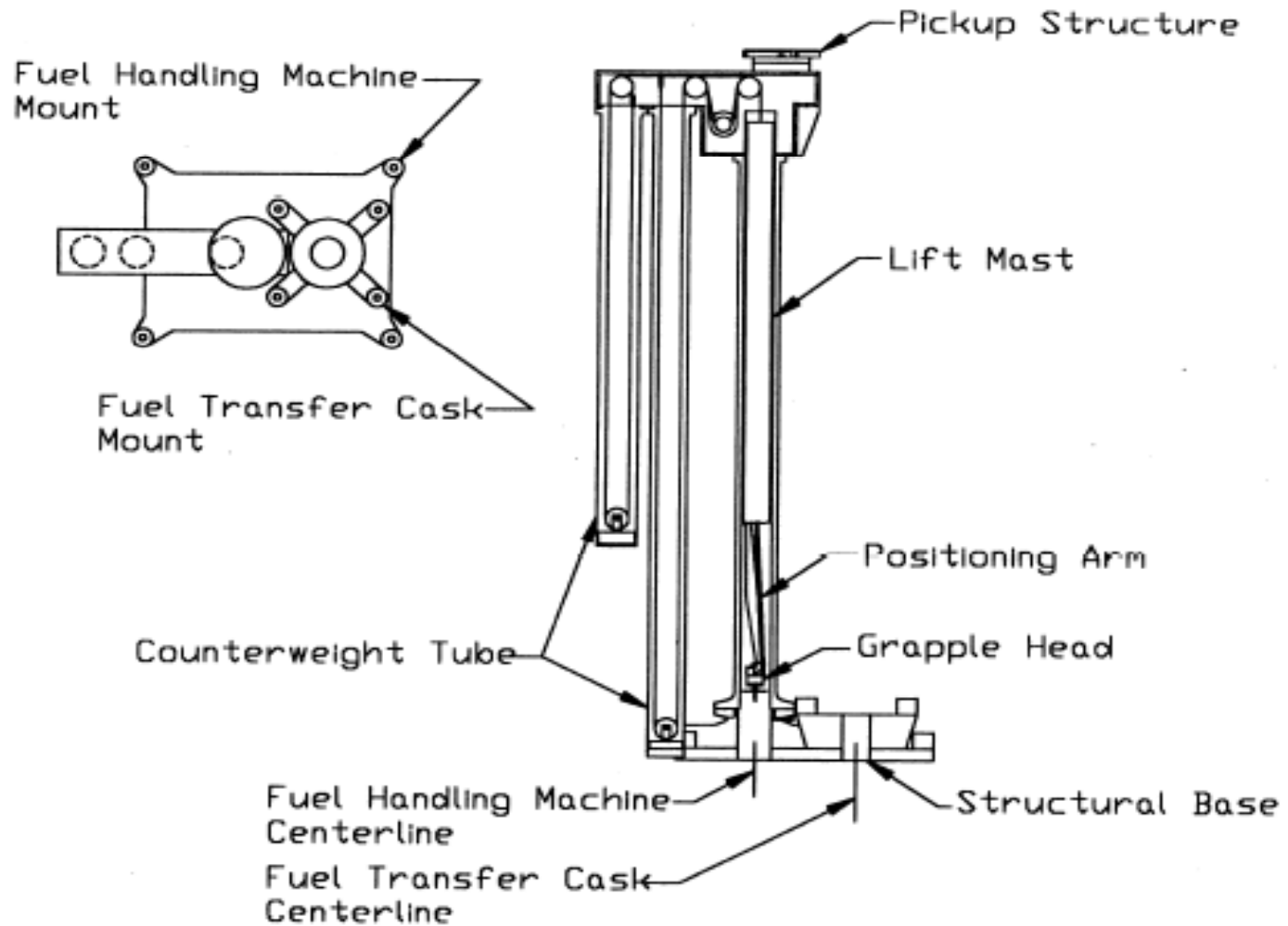

Fuel Transfer Cask - MHTGR

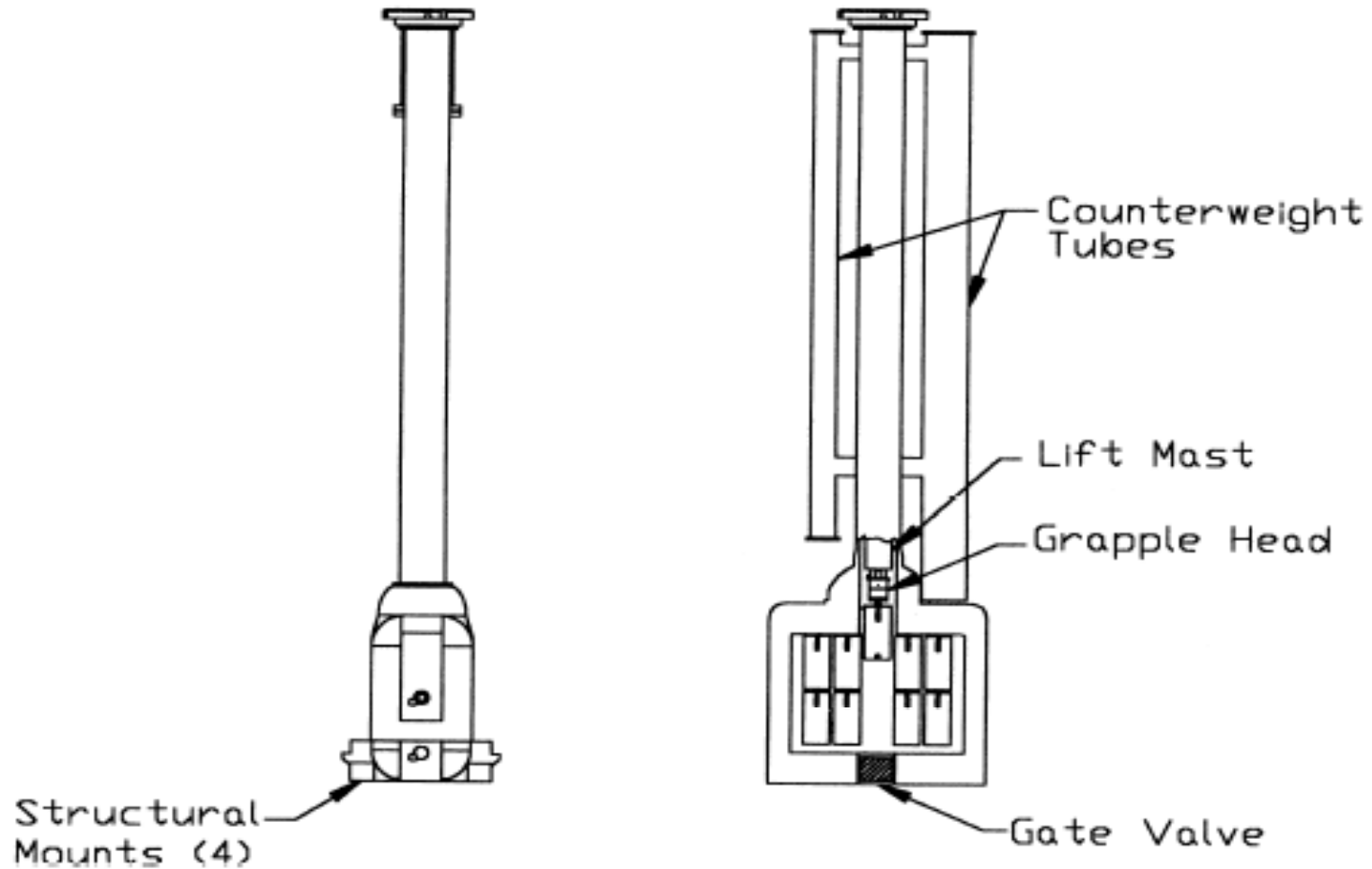

In-Vessel Refueling Operations - MHTGR

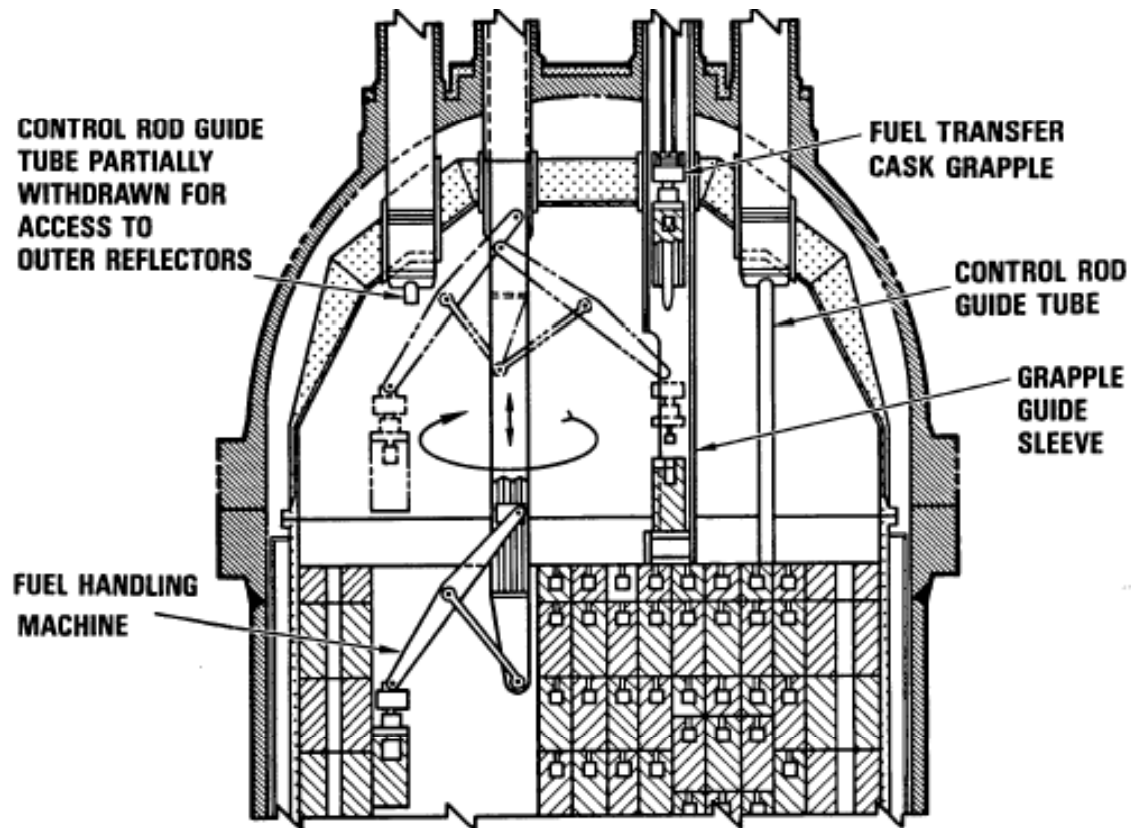

Arrangement of Refueling Equipment and Penetrations - MHTGR

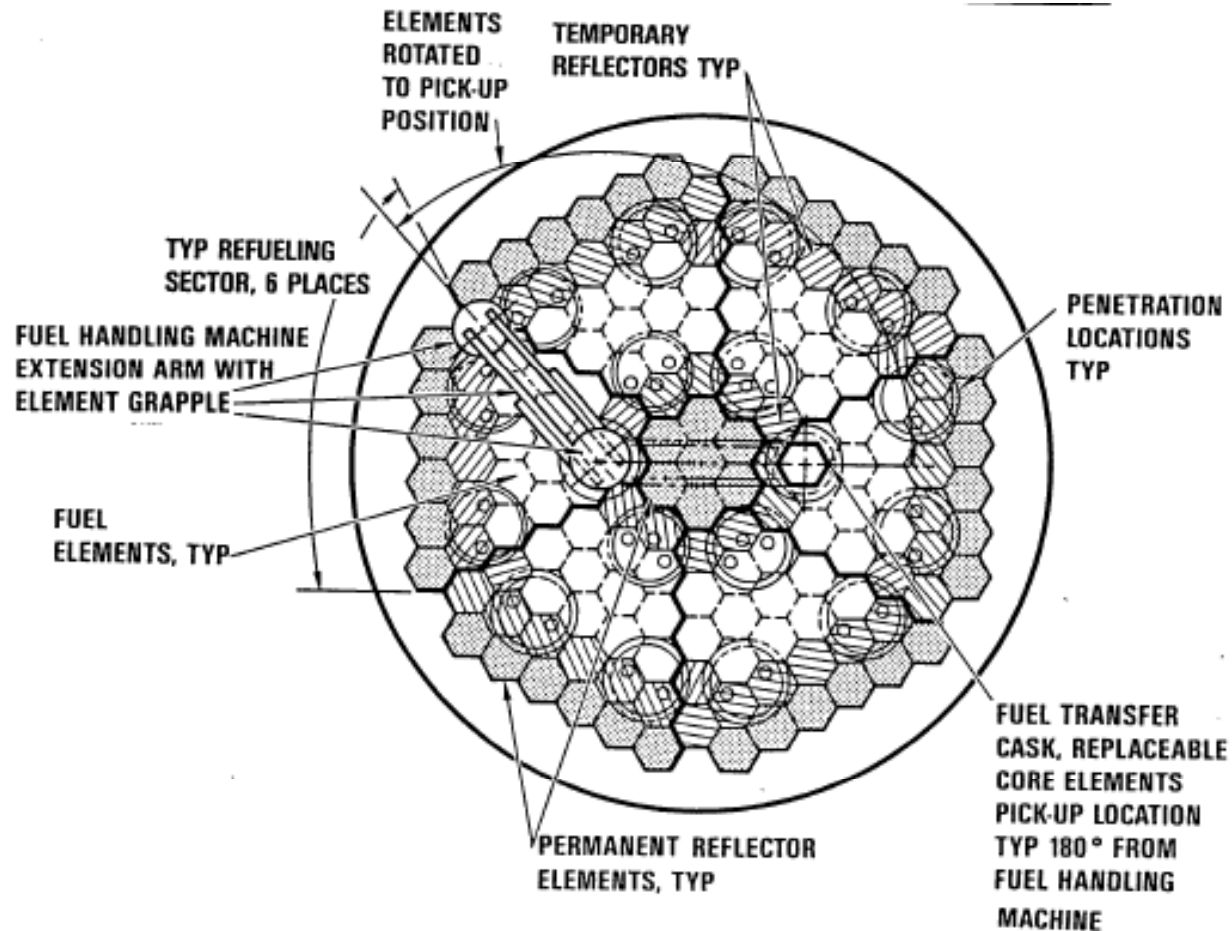

Local Storage Facility - MHTGR

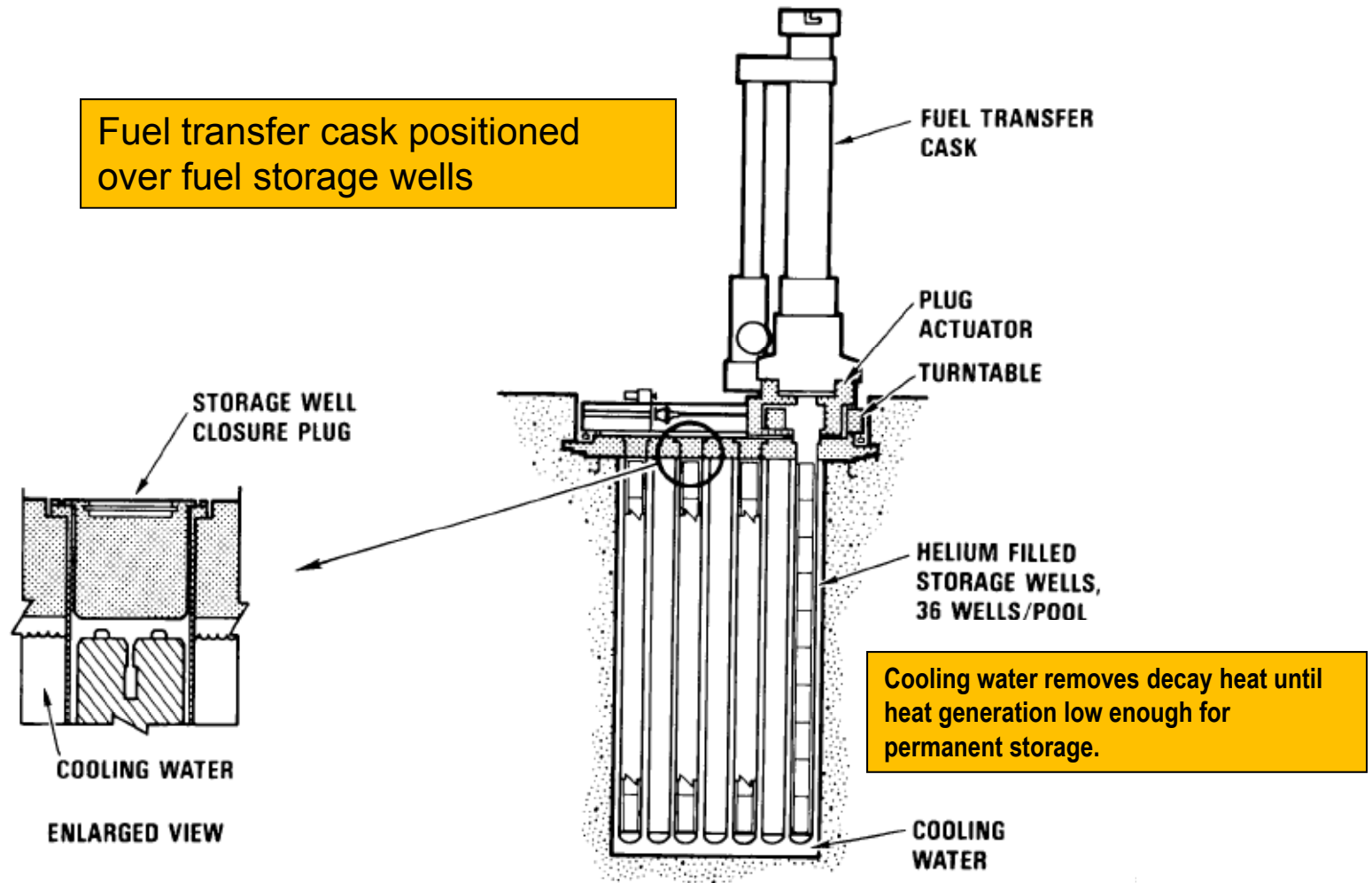

Refueling System Overall Process

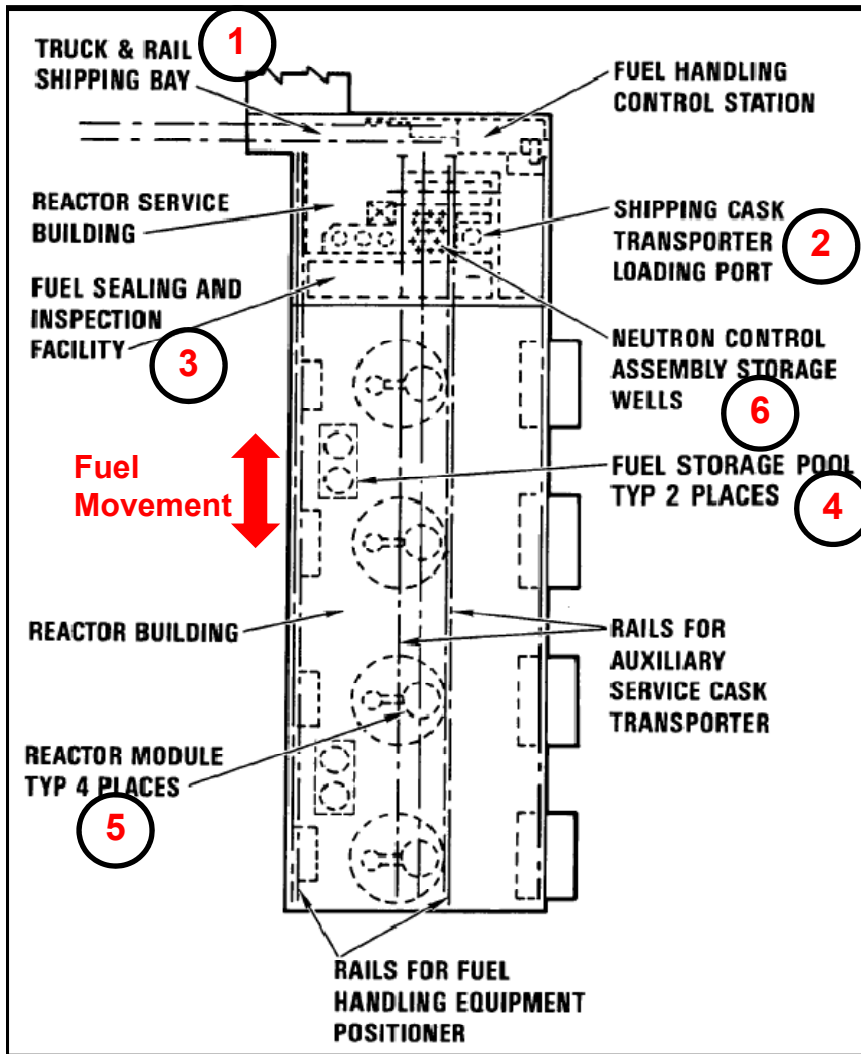

Location	Action
1	New-fuel received at Shipping Bay
2	Shipping Casks placed in Storage Racks
3	New-fuel Unsealed & inspected
4	Positioner moves new-fuel to storage pool
5	Transporter moves Auxiliary Service Cask to reactor module & removes Control Rod Drive
6	Transporter moves CR Drive to Neutron Control Storage Well
5	Positioner moves Fuel Handling machine & Fuel Transfer Cask to Reactor Module and removes 1/6 Sector of used-fuel
4	Positioner moves used-fuel to Storage Pool and places new-fuel & some used-fuel in Fuel Transfer Cask
5	Positioner moves Fuel to Reactor Module <ul style="list-style-type: none"> • New- & Used-fuel Placed in Reactor • Moves FHM & FTC to neutral position
6	Transporter moves Aux Service Cask to Neutron Control Storage Wells & retrieves Control Rod Drive
5	Transporter moves Aux Service Cask to Reactor Module <ul style="list-style-type: none"> • Replaces Control Rod Drive • Seals reactor • Moves Aux Service Cask to neutral position

OUTLINE

- Prismatic refueling system functions and requirements
- Refueling system design description
- ➔ • Fort St. Vrain experience
- Used fuel management plan

Fort St. Vrain Fuel Handling Machine

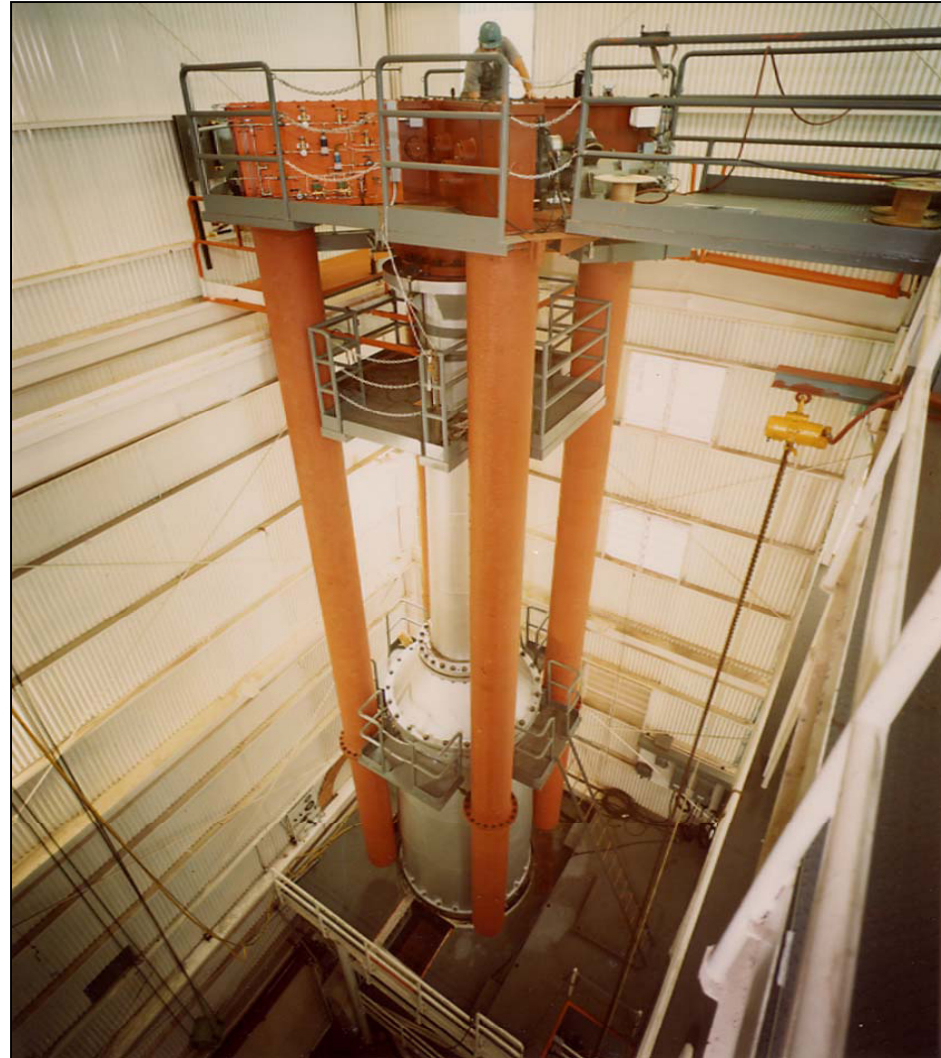

Fort St. Vrain Grapple Head

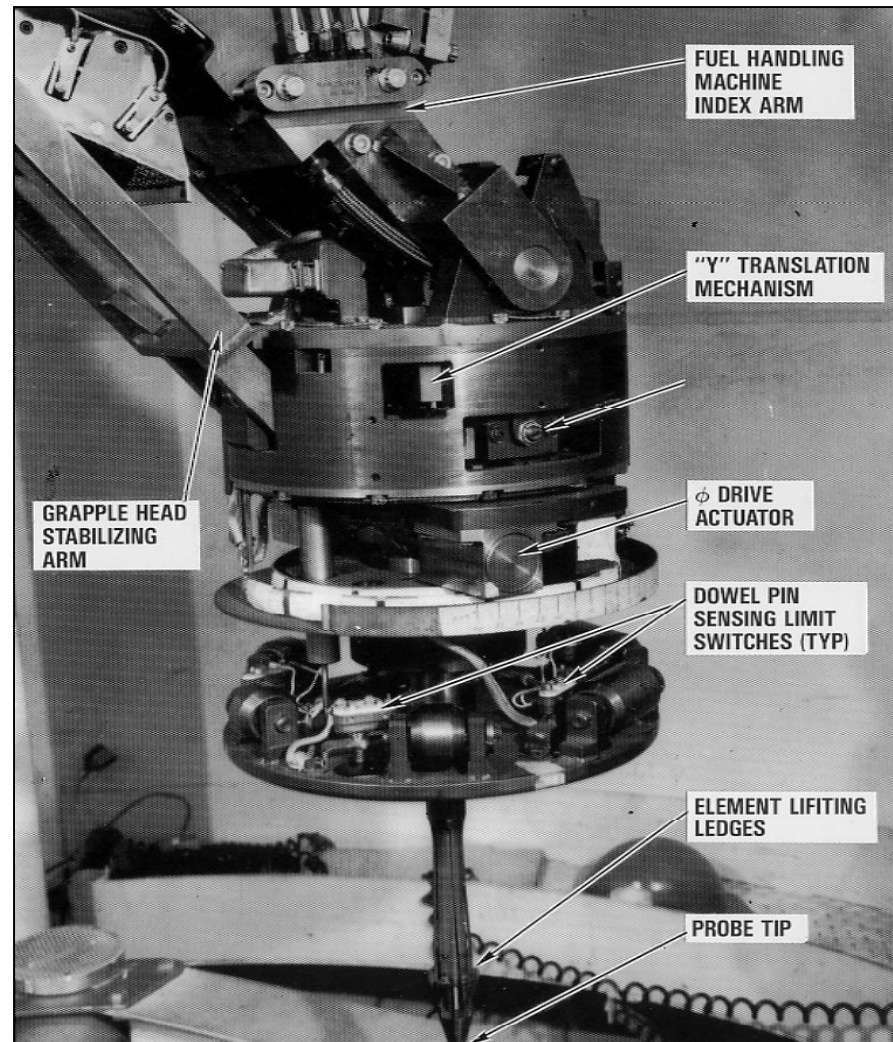

Lessons Learned and Key Features Proven at Fort St. Vrain

- **Reliable grappling of graphite fuel blocks**
- **Remote pickup and deposit for offset core alignment**
- **Fuel block handling speeds and acceleration and deceleration**
- **Use of dry-film and wet lubricant applications**
- **Shielding protection**
- **Control of primary coolant atmosphere**

OUTLINE

- Prismatic refueling system functions and requirements
- Refueling system design description
- Fort St. Vrain experience
- ➔ • Used fuel management plan

Used-Fuel Management Plan

- **Cool used fuel in local used fuel storage facility until fuel is ready for storage in dry storage casks**
- **Place used fuel in storage canisters in reactor service building**
- **Load storage canisters into concrete storage cask**
- **Move storage cask to on-site storage facility**
- **Store until final disposition is available**
- **Load storage canister into shipping cask**
- **Ship used fuel storage canisters to final disposition facility**

On-Site Used Fuel Storage Facility - MHTGR

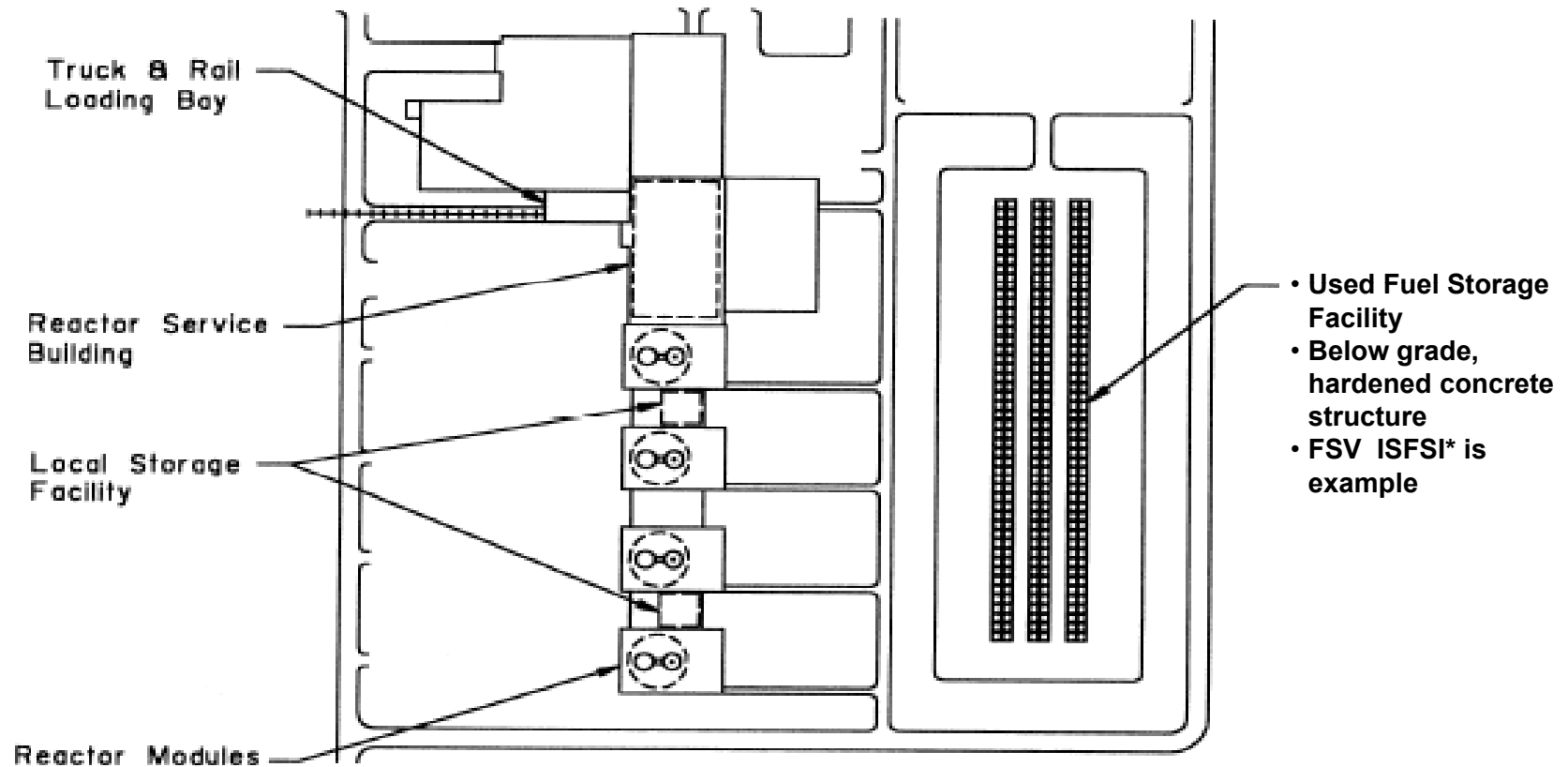

*ISFSI = Independent Safe Fuel Storage Installation

Summary

- **Refueling accomplished remotely using automatic, computer controlled operations**
- **Major equipment and facilities employed include:**
 - **Fresh fuel receipt and storage facility**
 - **Fuel handling machine**
 - **Fuel transfer cask**
 - **Fuel handling equipment positioner**
 - **Local, water-cooled used-fuel storage facility**
 - **Used-fuel packaging facility**
 - **On-site dry, used-fuel storage casks for long-term storage**
- **Basic refueling process and key equipment items proven at Fort St. Vrain**
- **Long-term storage of used-fuel accomplished using dry storage casks**

Suggested Reading

- **“Preliminary Safety Information Document for the Standard MHTGR”, HTGR-86-024, Section 9.1.1.**
- **“Conceptual Design Summary Report Modular HTGR Plant”, DOE-HTGR-87-092, Section 3.7**